

The TOWERMAK system is equipped with devices, such as:

- **An automatic separation of the metal sheet from the pile (heap):** This is a function carried out from a magnet and one of the suction cups that acts on the corner of the metal sheet.
- **Thickness measuring control:** It is a device to measure the thickness of the metal sheet before loading. It makes sure the reliability of the system also during the unmanned operations. In case the thickness is not adequate to the requirement of the laser machine cycle, the separation cycle is repeated.
- **Verification of unloaded metal sheet maximum height device** permit to avoid unloading operation of the processed metal sheet when has been reached the maximum height allowed on the unloading pallet.
- **Z axis fall safety device:** Avoid falls of the Z axis (the one that has a comb). It is a couple of pneumatic cylinders that blocks the fall of the comb arm by entering into specific positioned areas every 7,9 inch.
- **Fixed fencing system and protection with photocells** complete the supply.

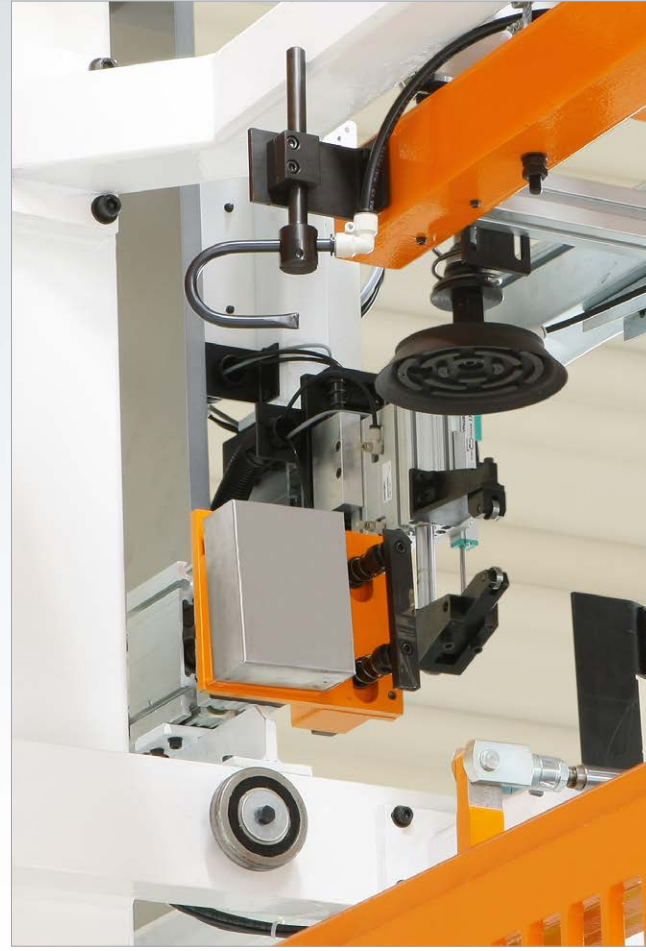

- **Magnetic Stripper:** When the suction cups handler is fully lift up magnetic stripper support the system to separate metal sheets.
- **Air Jet Blower:** The metal sheet separated by air jet blower when they are stick to each other.
- **Sheets Pneumatic Stripper:** One suction that moves separately up and down to shake the metal sheet for separating stuck.

CONTROLLER

Siemens brand controller supports up to 28 material codes in the system;

- Open system for the robot configuration,
- 5,7 inch touch screen with keypad (system can be run with touch screen or keypad)

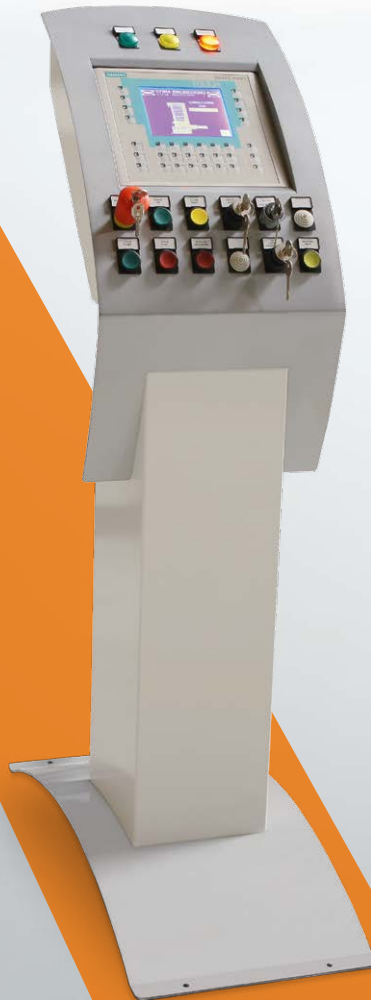

ERMAK USA Inc.
1260 Landmeier Road, Elk Grove Village, IL 60007
T: +1 847 640-7765 F: +1 847 640-7808
www.ermakusa.com | info@ermakusa.com
[/ermaksan.com.tr](https://www.facebook.com/ermaksan.com.tr) [/ermaksanmachine](https://www.instagram.com/ermaksanmachine) [/ErmaksanTV](https://www.youtube.com/channel/UC...)

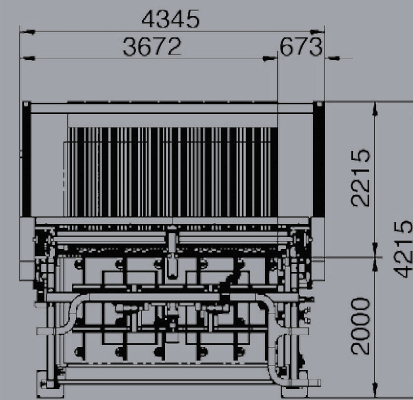
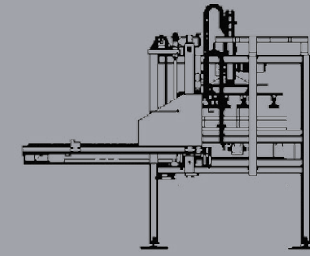
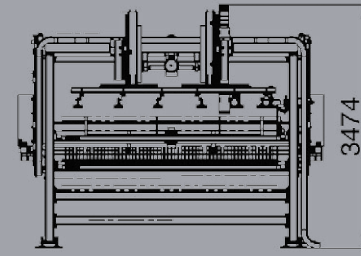

TECHNICAL FEATURES

Standard metal sheets	: up to 59x118 inch
Sheet thickness	: min: 0.05in max: 0,79in
Payload per pallet	: 6614 pounds
Loading height	: max. 5,9 inch
Unloading height	: max. 5,9 inch
Overall dimension	: 97x173x118 (h) inch
Z axis stroke	: 47,3 inch
Z axis speed	: 43,3 in/min
Horizontal comb stroke	: 63 inch
Comb speed	: 39,4 in/min
Suction cups vertical stroke	: 13,8 inch
Suction cup speed	: 9,8 in/min
Working cycle	: 120 seconds
Power and control unit	: SIEMENS

Fibermak-tower 01-ENG (inch) © All rights reserved.

FIBERMAK
► Momentum Gen-2

TOWER
Full Automatic Sheet Metal Loading & Unloading System



FIBERMAK

► Momentum Gen-2

TOWER

Full Automatic Sheet Metal Loading & Unloading System

CONTINUOUS CUTTING

Ermaksan Fibermak Momentum Gen-2 provides precision cutting and mass production by Tower.

The TOWERMAK is a system used for the unmanned loading/unloading management of metal sheets for 2D laser machine 59x118 inch metal sheets; guarantees high level reliability, highly flexibility and easy to be used.

The Advantages of **TOWER** Full Automatic Sheet Metal Loading and Unloading System;

- 24/7 working option,
- No unexpected stop,
- The competitive advantage for unit costs,
- Precision sheet metal protection against damages and scratches,
- The ideal solution for enterprises against stock area loss with multi-pallet stacking system in the tower.

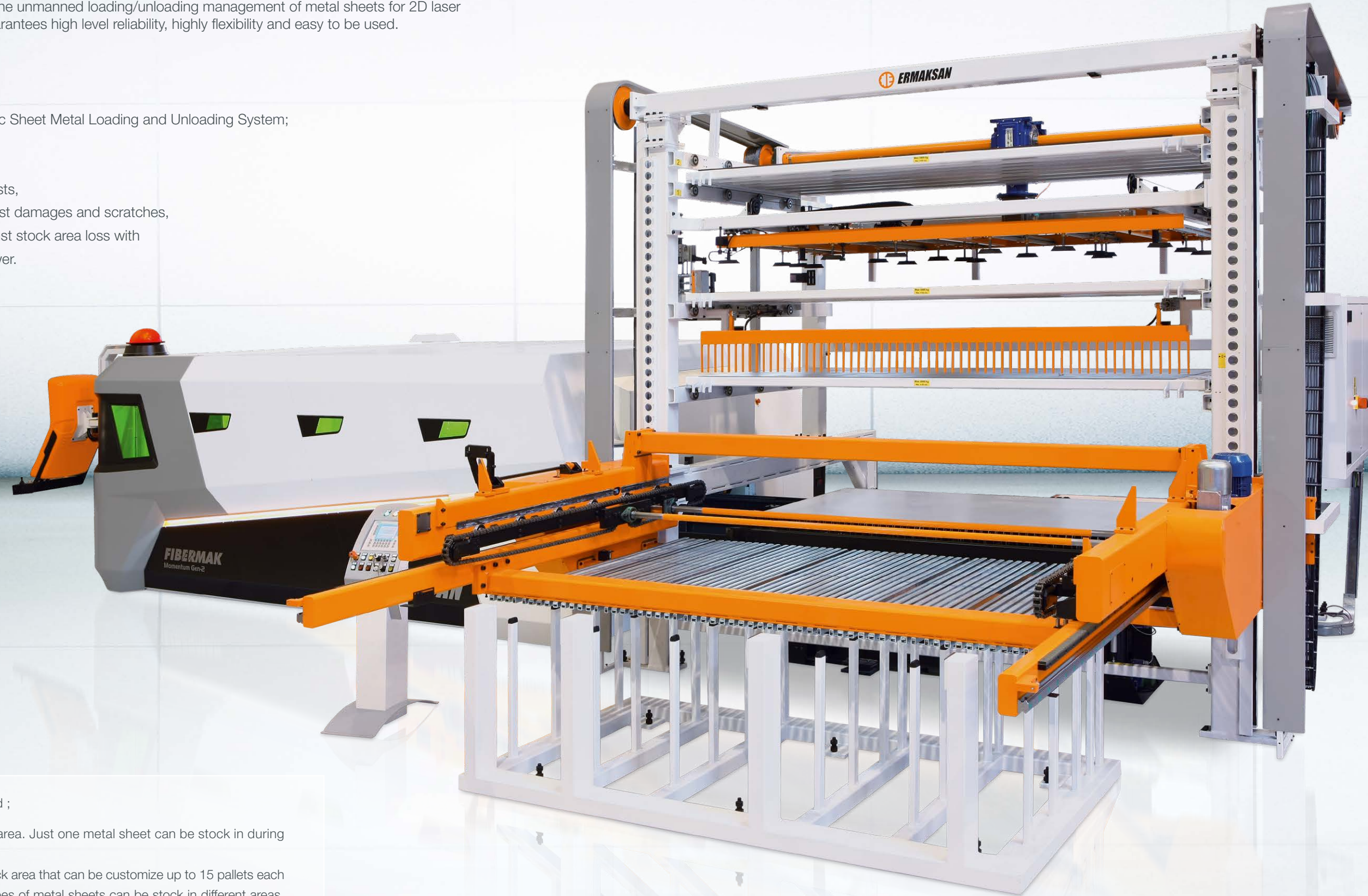

TOWER has two model according to demand ;

- **Basic Tower:** Standard 2 pallets for stock area. Just one metal sheet can be stock in during the process.
- **Compact Tower:** Minimum 3 pallets for stock area that can be customize up to 15 pallets each can payload 6610 pounds. Two different types of metal sheets can be stock in different areas. Also finished metal sheet can be stock in other area.



X Reference Arm: This arm provide you to reference metal sheet and precise handling for the suction cups.



Stock Area: Automatic system handle the sheet and place it in the proper stock area.



Suction cup device for lifting raw metal sheet: Is an arm with the grip placed over the loading pallet. The duty of this arm is to lift the raw metal sheet to permit the entrance of the comb device under the metal sheet lifter and deposit it on this comb device.